

TECHNICAL PARAMETER AND SPESIFICATION

DELIVERING TRUSTED & RELIABLE FOR YOUR X-RAY SOLUTIONS



X-ray Foreign Object Intelligent Inspection Expert
688531.SH



Mechanical and electrical specs.	Dimensions: 2005mm(L) × 1280mm(W) × 2195mm(H) Weight: 700KG (approximately) Body Material: Food standard SS304. Conveyor belt: Food grade PU; Lead & Curtain: RoHS & food grade. Power Requirements: 220VAC, 2.5KVA, 50Hz/60Hz
X-ray Tube	-Type: Closed - Max Voltage: 120KV -Power: 480W
Detector	800mm; 0.4mm high resolutions
Tunnel size	Tunnel Size: 600mm(W)*300mm(H); Conveyor Speed: 10-60m/minutes (adjustable depending on the -product dimension). Max Load Weight: 20KG
Inspections accuracy (Sensitivity)	Stainless Steel Wire: 0.4*2mm; Stainless Steel Ball: 0.4mm, Ceramic ball: 1.5mm; Glass: 2.0mm,
Rejections	Reject sorting unit using push rods or flip (optional)
Image management	Auto images save/print/analyses.
Radiations leakage	<1μSv/hour.
Ingress protection	IP66 for tunnel, it safe to wash the conveyors.; IP65 for other parts.
Working environments	Working Temp: 0-40°C; Relative Humidity: 30-80%; No Air conditioner room required.
Display	15.6" Touch screen LCD
Operating Systems	Windows 10.
Software & Detections advantage	AI deep learning, Defect detections for empty shell or half shell.

* Specifications are subject to change without notice, All trademarks are the property of the system maker.

OPTICAL PATH DIAGRAM

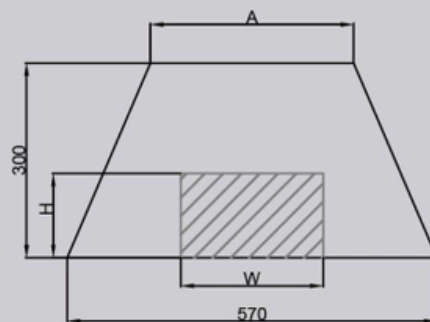

H	W
300	315
200	400
100	485
50	530
10	560
0	570

UNX6030-N

LARGE PACKAGE/BOX FOOD X-RAY FOREIGN BODY DETECTOR EQUIPMENT



PT. FAIKA SARANA MULIA

DELIVERING TRUSTED & RELIABLE FOR YOUR X-RAY SOLUTIONS





6 PLANTS AND R&D CENTERS

30000+
Customer's solutions



Wuxi Unicomp X-Vision Technology Co., LTD is a wholly-owned subsidiary of Unicomp Technology (Group) Co., Ltd.. It is an intelligent detection equipment enterprise that takes X-ray imaging technology as its core and focuses on the research and development, manufacturing and service of foreign object detection technology. Comprehensively and deeply focus on the research and development and innovation of foreign object detection technology.

The product is widely used in the detection of foreign objects and defects in the fields of food, agricultural and sideline products, medicine, daily necessities, etc.



DELIVERING TRUSTED & RELIABLE
FOR YOUR X-RAY SOLUTIONS



UNX6030-N

Application Scenarios



Cold chain fruits and vegetables



Roasted nuts



Milk Powder



Whole grains nuts

Features :

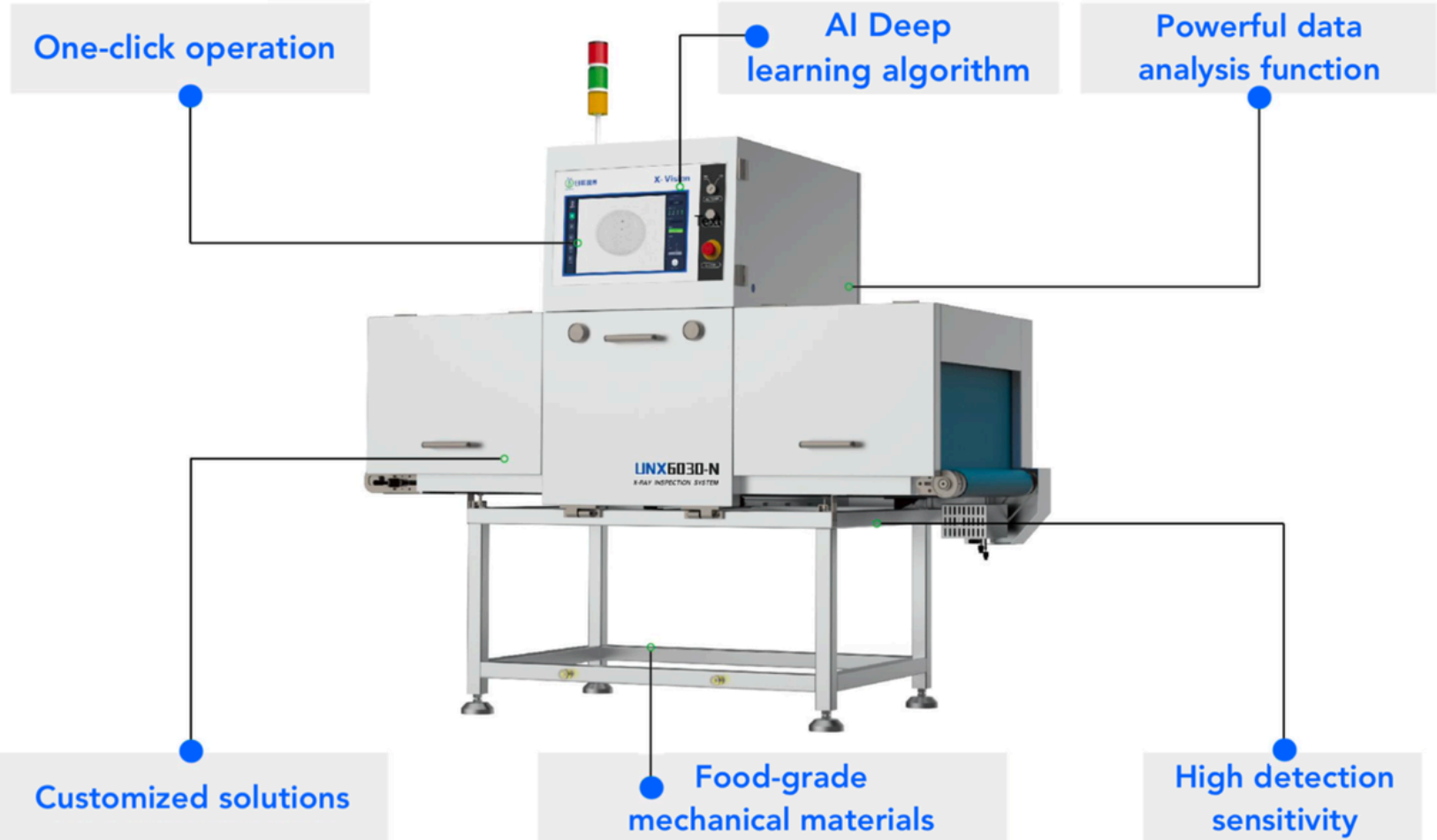

Detect Pictures

